



Kingspan Ecobac 160 PN /160 PN HPA Data Sheet

Pneumatically-operated smoke & heat exhaust vent for metal roofs



Daylighting Solutions
Natural Ventilation Solutions
Smoke Management Solutions
Service & Maintenance
Building Automation



Kingspan Ecobac 160 PN / HPA

Description

CE- and NF-certified, pneumatically-controlled smoke and heat exhaust vent (SHEV) with 160° opening. Designed for installation in composite, steel, or aluminium roofs. 160 PN HPA version (High aeraulic performance).

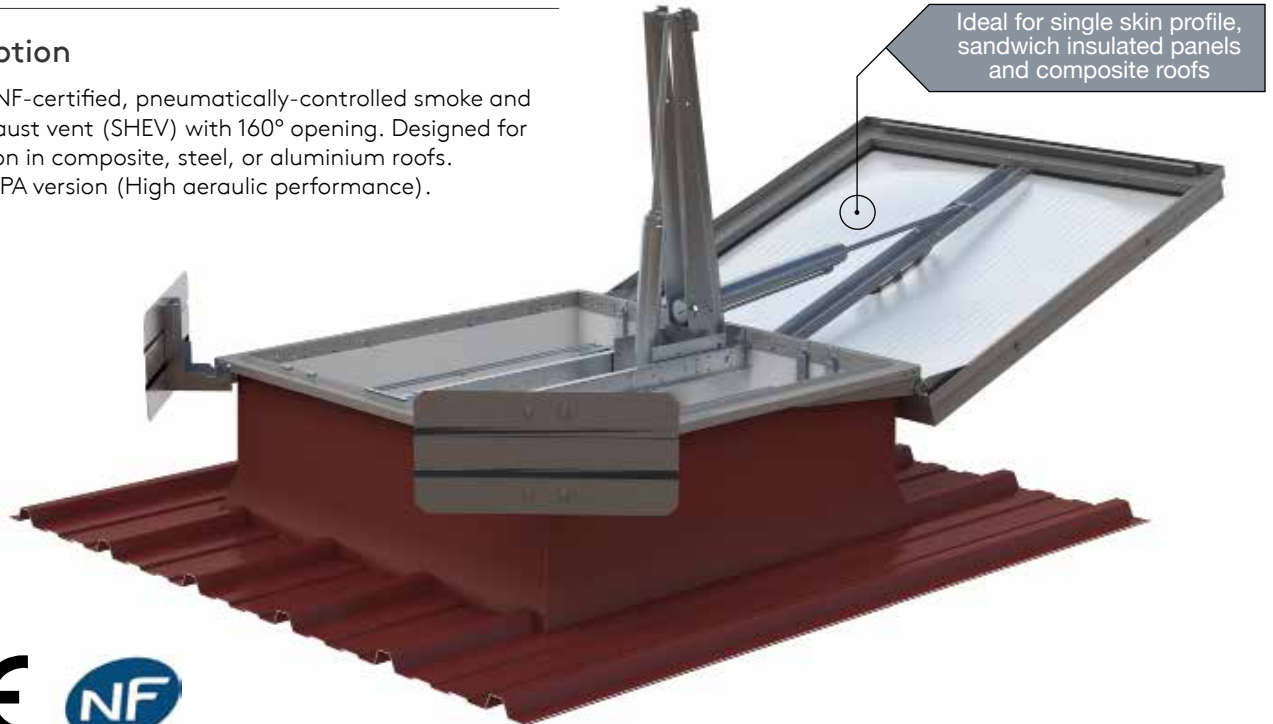

Advantages

- CE-certified smoke & heat exhaust vent compliant with EN 12101-2 (CE certificate of conformity no.: 0333-CPR-219014).
- NF-certified SHEV smoke & heat exhaust vent compliant with NF S 61937-1.
- Exterior gel coat finish for a smooth surface and a longer life.
- Unique patented locking system offering excellent wind load capability.
- Pneumatic ventilation as standard, at no extra cost.
- Electrical ventilation available on request.
- Enhanced waterproofing on lid: aluminium F frame with patented, factory-mounted seal.
- Compliant with the CETIM Machinery Directive to ensure optimal operational safety.
- Metal deflectors for higher smoke exhaust (HPA version).
- Control system installed by our teams.

Standard description

The building's natural smoke ventilation will be provided by Kingspan Light + Air Ecobac 160 PN smoke and heat exhaust vents. These units are CE-certified according to EN-12101-2, NF-certified SHEV and compliant with the EC Machinery Directive. Performance levels meet the requirements of French regulations, including the 10,000-cycle ventilation function. The base can be coloured to match the roof. The vent opens to 160° and features a high resistance locking mechanism built into the kerb height. Multiwall polycarbonate lid with fire rating B -s1, d0 (M1) and thermofuse rated at 93°C.



Description

Opening lid

The frame is made of galvanised steel. In the safety open position, it opens to 160° powered by two pneumatic drives. In the stand-by position, it locks under the fixed frame using its unique patented system.

Operating system

A manually initiated device (DCM) controls the system, pneumatic opening and closing, that complies with NF S 61-938. The smoke exhaust vent is equipped with a factory-installed thermofuse, rated at 93°C, to command opening.

Base

The base is made of glass-reinforced polyester (GRP), with RAL colour finish to blend in with the roof profile. Sandwich panel base available for insulated steel cladding panels. Other profiles are available on request.

ISO+ range

The ISO+ reinforced insulation range limits heat losses.

Gutter

At the top, it ensures effective evacuation of rainwater.

Glazing

Opalescent multiwall polycarbonate (MWPC) lid, 10mm thick, for the standard version. It is integrated into a fully sealed aluminium F frame. Fire rating: B-s1, d0 (M1). (Different types of glazing available)

Wind baffles

(for the HPA version)
Metal wind baffles improve the aeraulic efficiency of the smoke vent.

Pneumatic drives

Both pneumatic drives are equipped with stroke end cushioning.

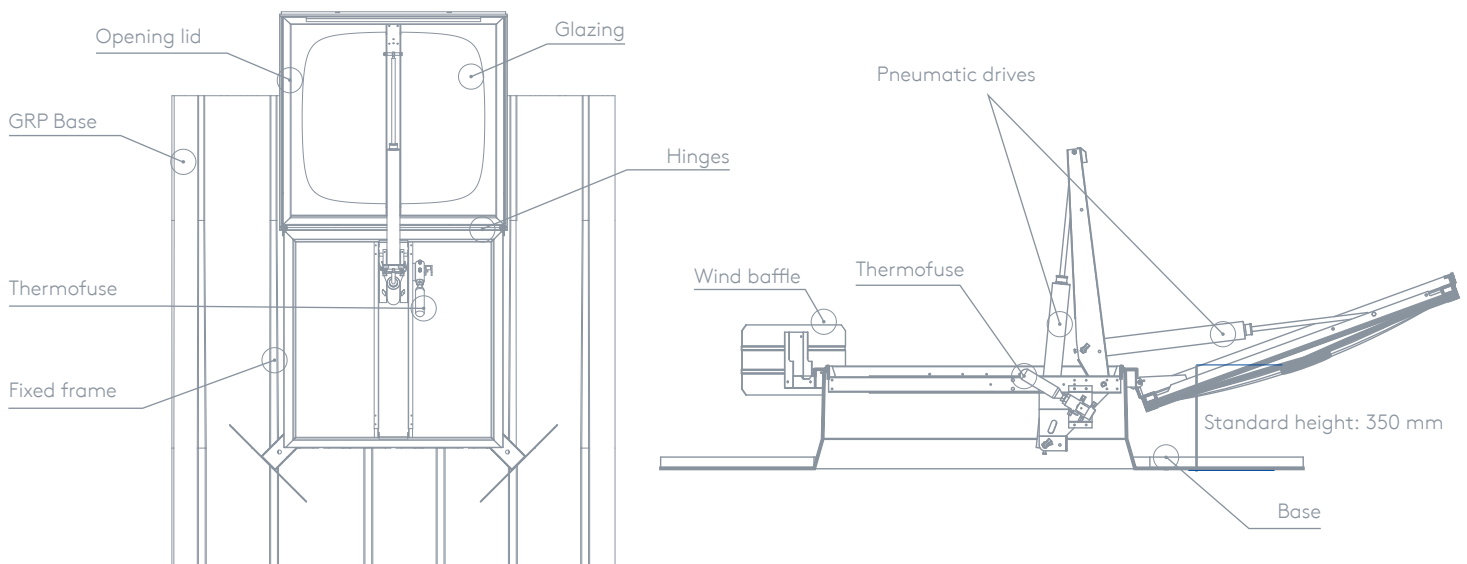

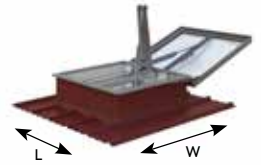

Ecobac 160 PN | Aeraulic performance

PROFILE	Dim. (W x L)	Surface area of smoke exhaust vent (m ²)	Aa (m ²)	
			Standard	Burglar- proof grid
OAC 5 wave 1/2	110 x 110	1.21	0.80	0.73
	110 x 150	1.65	1.09	1.02
	110 x 240	2.64	1.73	1.68
OAC 6 wave 1/2	110 x 110	1.21	0.80	0.73
	110 x 290	3.19	2.08	2.06
SUPERONDE	150 x 150	2.25	1.26	1.19
PST 230	110 x 110	1.21	0.80	0.73
	110 x 180	1.98	1.29	1.22
H 3 333 39 T (PROMISOL 1001 T)	110 x 110	1.21	0.80	0.73
	110 x 180	1.98	1.29	1.22
NERV. 3 45 1000 TS (ONDATHERM 101)	150 x 150	2.25	1.26	1.19
	120 x 250	3.00	1.88	1.84
	130 x 250	3.25	1.94	1.92
JI 45 333 1000 (JI ROOF + PLUS OR PIR)	160 x 180	2.88	1.54	1.50
NERV. 3 35 1000 T (ONDATHERM 201)	130 x 250	3.25	1.94	1.92

- SL250
- SL500 possible on request
- Available in roof access version

PROFILE	Dim. (W x L)	Surface area of smoke exhaust vent (m ²)	Aa (m ²)	
			Standard	Burglar- proof grid
H 4 250 35 T	110 x 110	1.21	0.80	0.73
	110 x 180	1.98	1.29	1.22
	150 x 150	2.25	1.26	1.19
JI 40 250 1000 ROOF (JI ECO PIR)	120 x 250	3.00	1.88	1.84
	130 x 250	3.25	1.94	1.92
JI 33 250 1000 CS	160 x 180	2.88	1.54	1.50
	130 x 250	3.25	1.94	1.92
NERGAL 3 45 1000 T	130 x 250	3.25	1.94	1.92
ASTRON PR ASTRON LPR 1000	130 x 170	2.21	1.34	1.27
	130 x 250	3.25	1.94	1.92
ISODUPLEX	130 x 250	3.25	1.94	1.92
METECNO	130 x 250	3.25	1.94	1.92
PROFILACIER 35 C	130 x 250	3.25	1.94	1.92
JI 37 250 1000 (VULCASTEEL ROOF) (KS 1000 RF)	110 x 110	1.21	0.80	0.73
	150 x 150	2.25	1.26	1.19
	130 x 250	3.25	1.94	1.92
(KS 1000 RW)	110 x 110	1.21	0.80	0.73
	150 x 150	2.25	1.26	1.19
	120 x 250	3.00	1.88	1.84
JI 29 283 850	110 x 110	1.21	0.80	0.73

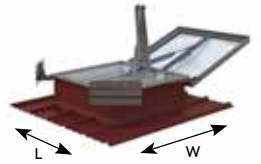

Ecobac 160 PN HPA | Aeraulic performance with wind baffles

PROFILE	Dim. (W x L)	Surface area of smoke exhaust vent (m ²)	Aa (m ²)	
			Standard	Burglar- proof grid
OAC 5 wave 1/2	110 x 110	1.21	0.97	0.90
	110 x 150	1.65	1.31	1.24
	110 x 240	2.64	2.05	2.00
OAC 6 wave 1/2	110 x 110	1.21	0.97	0.90
	110 x 290	3.19	2.38	2.36
SUPERONDE	150 x 150	2.25	1.75	1.68
PST 230	110 x 110	1.21	0.97	0.90
	110 x 180	1.98	1.56	1.49
H 3 333 39 T (PROMISOL 1001 T)	110 x 110	1.21	0.97	0.90
	110 x 180	1.98	1.56	1.49
NERV. 3 45 1000 TS (ONDATHERM 101)	150 x 150	2.25	1.75	1.68
	120 x 250	3.00	2.21	2.17
	130 x 250	3.25	2.31	2.29
JI 45 333 1000 (JI ROOF + PLUS OR PIR)	160 x 180	2.88	2.06	2.02
NERV. 3 35 1000 T (ONDATHERM 201)	130 x 250	3.25	2.31	2.29

- SL250
- SL500 possible on request
- Available in roof access version

PROFILE	Dim. (W x L)	Surface area of smoke exhaust vent (m ²)	Aa (m ²)	
			Standard	Burglar- proof grid
H 4 250 35 T	110 x 110	1.21	0.97	0.90
	110 x 180	1.98	1.56	1.49
	150 x 150	2.25	1.75	1.68
JI 40 250 1000 ROOF (JI ECO PIR)	120 x 250	3.00	2.21	2.17
	130 x 250	3.25	2.31	2.29
JI 33 250 1000 CS	160 x 180	2.88	1.54	1.50
	130 x 250	3.25	0.97	2.29
NERGAL 3 45 1000 T	130 x 250	3.25	0.97	2.29
ASTRON PR ASTRON LPR 1000	130 x 170	2.21	1.73	1.66
	130 x 250	3.25	2.31	2.29
METECNO	130 x 250	3.25	2.31	2.29
PROFILACIER 35 C	130 x 250	3.25	2.31	2.29
JI 37 250 1000 (VULCASTEEL ROOF) (KS 1000 RF)	110 x 110	1.21	0.93	0.90
	150 x 150	2.25	1.75	1.68
	130 x 250	3.25	2.31	2.29
(KS 1000 RW)	110 x 110	1.21	0.97	0.90
	150 x 150	2.25	1.75	1.68
	120 x 250	3.00	2.21	2.17
JI 29 283 850	110 x 110	1.21	0.97	0.90

Performance and classifications (according to EN 12101-2)*

Name	Class	Meanings / Observations
Operation	Type B	Opened and closed from the ground
Effective surface area	Aa	See "Dimensions and aeraulic performance" table
Reliability	Re 300 (10,000 cycles in ventilation)	Number of open/close smoke ventilation test cycles
Snow Load	SL250	Permissible load in the smoke ventilation test (N/m ²)
	SL500	Oversize 130 x 250
Wind Load	WL 1500	Resistance to wind force (in N/m ²)
Low temperature	T (00)	Unit meets French requirements
Resistance to heat	B300	Operating test at a temperature of 300°C

* The exact technical specifications depend on the dimensions of the units. Requires validation on a case-by-case basis.

Conditions of use

Name	Class
Minimum opening pressure (smoke ventilation)	10 bar*
Minimum opening pressure (ventilation)	6 bar*
Minimum closing pressure	8 bar*
Maximum inclination and orientation for the kerb bearing plane	21° hinge pin parallel to ridge and hinge at top

* The exact technical specifications depend on the dimensions of the units. Requires validation on a case-by-case basis.



Ecobac insulated bases are a perfect match for the Kingspan KS1000 roof panel - the example is of ECOBAC 160 on KS 1000 RW QuadCore™ panels. Thickness of insulation to be defined.

Installation examples

Installation of the bases is governed by the applicable Unified Technical Document (D.T.U. 40.30 series) and French standards relating to the sheets they are associated with, in the following domains:

- overlaps
- Installation of additional waterproofing if necessary
- attachment method.

In all cases, a steel H beam is required.

You will be sent a custom steel H beam drawing:

- on request with your quotation
- systematically when you place your order
- or see all our H beam drawings on www.kingspan.com/gb/en-gb

Principle of installing "sandwich" bases:

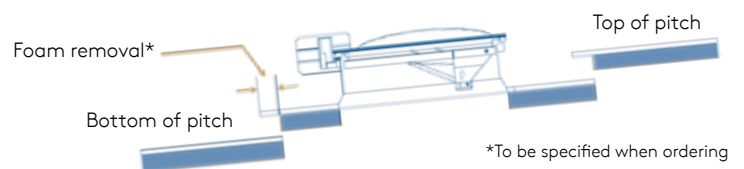

Foam removal to the left

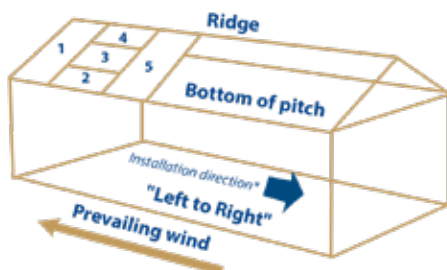

Foam removal to the right

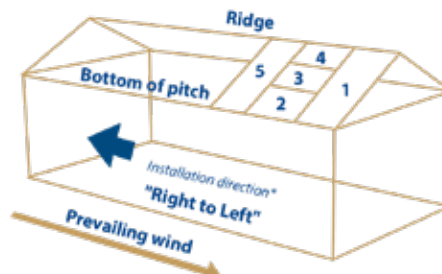

The numbers indicate the order of assembly

Options

Kerb and equipment

1. 1200 joule burglar-proof & fall protection grid

The Kingspan Light + Air RE grid satisfies CRAM recommendations for the protection of personnel working on roofs, and ensures compliance with the French Labour Code. It passed the standardised test for resistance to a person tripping and falling over: dynamic 1,200 Joule test. (see product data sheet).



2. Sandwich panels

For sandwich panel roofs, Ecobac can be delivered with a double wall GRP base, featuring up to 200 mm of polyurethane foam insulation. The thickness of insulation, direction of installation, roof laying and colours of the two sides must be specified when ordering.

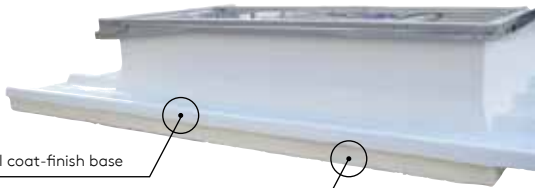

Gel coat-finish base

Polyester-coated polyurethane foam

3. Stroke end contacts

Two position contacts (safety position /standby position) can be connected to a control panel. This system allows you to check the position of all vents without climbing on the roof. This option is required when installing the SHEV in a Category A or B Fire Safety System.



4. Reinforced thermal insulation

The ISO+ reinforced insulation range provides better airtightness and reduces heat loss through efficient MWPC glazing (16 or 32mm), an insulating seal between the lid and the kerb.

ISO+ range

5. Without thermofuse

Useful option, for example, if regulations require the fire detection system to control smoke ventilation.

6. Steel Ecobac

For specific cases, Ecobac can be built with a fully steel base.

Asbestos-cement certification



Kingspan Light + Air is certified to work in buildings containing asbestos and on composite roofs, which can be fragile.

Specially for Roof Access

Roof access

For easy roof access, the opening vent features a remote mechanism and can be fitted with a variety of options: hand rail, 1200 joule opening burglar-proof and fall-through protection grid, ladder attachment bar. (see data sheet).



160° pneumatic ventilation



Delivered by the unit without modification, at no additional cost. Control is achieved by a pneumatic "comfort control panel" enabling priority smoke ventilation and normal ventilation. CE certification is also valid in this configuration. (Caution, the ventilation function is not available for the 130 x 250cm version)

Electric ventilation

Ventilation control can also be ensured by a 230V electric actuator with a 300 mm stroke. For smoke ventilation, the actuator is unlocked automatically.



Types of glazing

1. Multiwall polycarbonate lid

Refer to the table on the right

Other details available on request.



Type
MWPC - Opalescent - 10 mm - 4 walls
MWPC - Opalescent - 16 mm - 7 walls
MWPC - Opalescent - 32 mm - 5 walls
MWPC - Translucent - 10 mm - 4 walls
MWPC - Translucent - 16 mm - 7 walls
MWPC - Translucent - 32 mm - 5 walls
MWPC - IR Gold - 10 mm - 4 walls
MWPC - IR Gold - 16 mm - 5 walls
MWPC - IR Gold - 16 mm - 7 walls
MWPC - IR Gold - 32 mm - 5 walls
MWPC - Grey opaque - 10 mm - 4 walls
MWPC - Grey opaque - 16 mm - 7 walls

2. Polyester lid and dome

Completely opaque lid with black interior to prevent light reflection.

Suitable for use on sites where overhead lighting is to be avoided: cellar, cinemas, etc. Also suitable for sites exposed to chemical agents or an aggressive environment.

Thickness: 25 mm. Light transmission: 0%.

3. Aluminium lid

This lid has the best fire rating:

A2 - s1, d0 (M0). Not combustible.

Thickness: 50 mm. Light transmission: 0%.

Thermal transmittance coefficient:

$U = 0.8 \text{ W/m}^2 \cdot \text{K}$.

4. PMMA dome

Polymethyl methacrylate dome. Single or double wall.

Fire rating: E (M4).



Solar protection

5. ECOSUN Sunshade

The ECOSUN Sunshade provides a sustainable and economical solution to the problem of overheating in buildings. It is a high performance aluminium system, combined with the multiwall polycarbonate glazing in our rooflights. CSTB tests show that the energy transmission factor is only 15% (see product data sheet).

6. Detachable external sun screens

Made to measure fabric, PVC coated for better ageing, with reinforced edges and eyelets. The screens are delivered ready to be installed and are secured using a bungee cord threaded through the eyelets.

At your service:

Kingspan Light + Air is a manufacturer as well as a service provider with a network of service engineers and in-house CFD and fire engineering expertise. Proper, preventative, pre-emptive maintenance of Smoke & Heat Exhaust Systems undertaken by qualified specialists will not only ensure the highest levels of safety and security but also mean savings in time and money.

The comfort of a partner who takes care of everything: ask your local representative for more information about the services available in your country.



Certifications



INTERNATIONAL

Kingspan Light + Air

E: kla.international@kingspan.com

www.kingspanlightandairinternational.com

For the product offering in other markets please contact your local sales representative or visit www.kingspanlightandairinternational.com

Care has been taken to ensure that the contents of this publication are accurate, but Kingspan Limited and its subsidiary companies do not accept responsibility for errors or for information that is found to be misleading. Suggestions for, or description of, the end use or application of products or methods of working are for information only and Kingspan Limited and its subsidiaries accept no liability in respect thereof.

Kingspan-LA_ECOBAC-160-PN_EN-INTL_May-2019

