

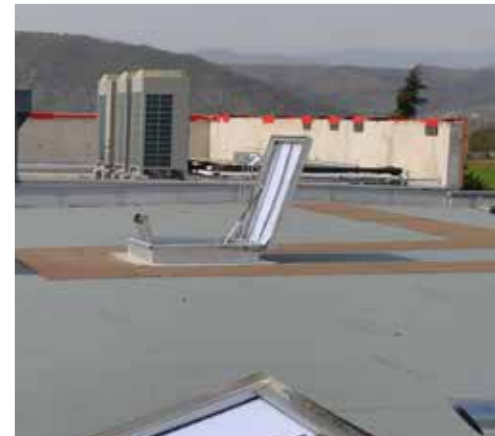

Kingspan Ecofeu 160 PN /160 PN HPA Data Sheet

Pneumatically-operated smoke exhaust vent
for waterproofed roofs



Daylighting Solutions
Natural Ventilation Solutions
Smoke Management Solutions
Service & Maintenance
Building Automation





Kingspan Ecofeu 160 PN /160 PN HPA

Description

Smoke & heat exhaust vent (SHEV), CE-certified according to EN 12101-2 standard and NF-certified according to NFS 61937-1 and 61937-7, with a 160° opening, pneumatic operating system, designed for installation in "waterproofed support" roofs.

Version 160 PN HPA:
High-Performance Aeraulic Wind baffles.

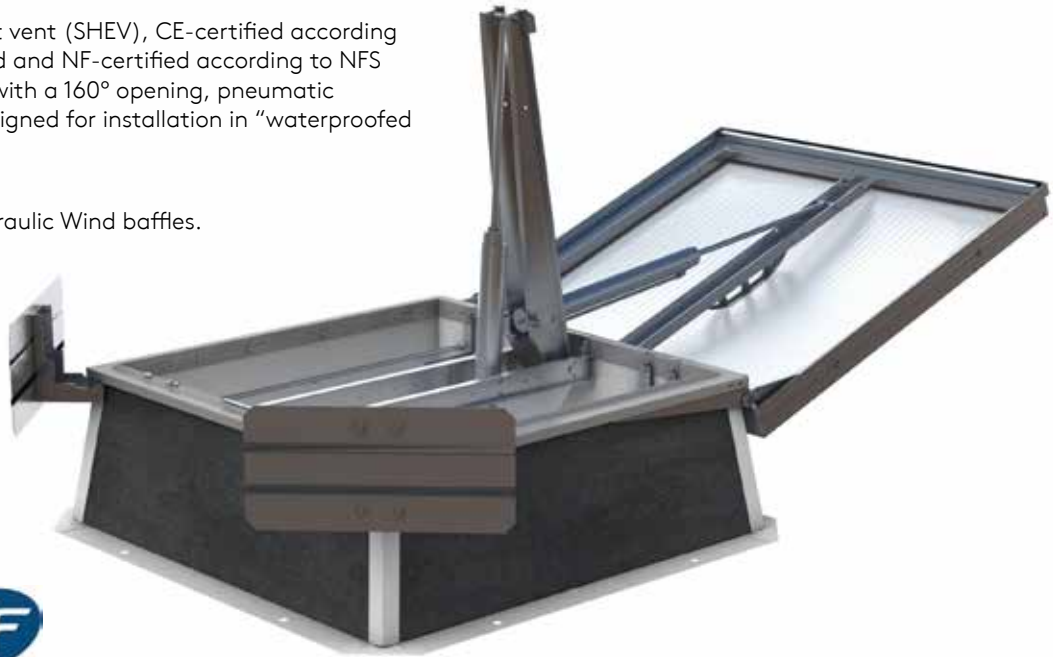

Advantages

- Unique patented locking system offering high resistance to winds.
- Pneumatic ventilation as standard, at no extra cost.
- Electric ventilation available.
- The ISO+ solution optimises exhaust vent insulation: 30% improvement compared with a standard unit. Urc: 1.7 W/m².K for a 32mm MWPC lid.
- Enhanced waterproofing on lid: aluminium F frame with patented, factory-mounted seal.
- Additional sound-proofing.
- Compliant with the CETIM Machinery Directive to ensure optimal operational safety.
- Fitted with metal wind baffles for better smoke ventilation (HPA version).
- The unit is delivered "ready for installation", with factory-mounted wind baffles (HPA version).
- Control system installed by our teams.
- CE-certified smoke exhaust vent compliant with NF EN 12101-2 (CE compliance certificate no.: 0333-CPR-219014).
- NF-certified SHEV smoke exhaust vent compliant with NF S 61937-1.

Standard description

The building's natural smoke ventilation will be ensured by Ecofeu 160 PN smoke exhaust vents from Kingspan Light + Air, CE-certified compliant with standard EN 12101-2, NF-certified SHEV and compliant with the Machinery Directive. Performance categories meeting requirements of French legislation, including the 10,000-cycle ventilation function. Galvanised, insulated 400mm high kerb, 160° opening lid with high-strength locking mechanism integrated into the height, opalescent multiwall polycarbonate lid with fire rating B-s1, d0 (M1) and thermofuse set at 93°C and, for the 160 PN HPA version, aluminium wind baffles.

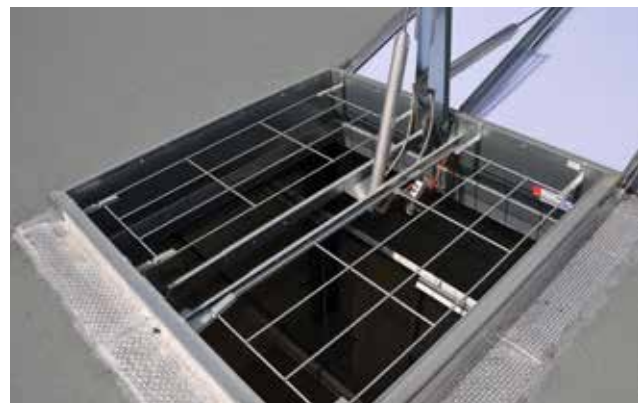

Description

Opening lid

The frame is made of galvanised steel. In the safety position, it is opened 160° powered by a pneumatic drive. In the stand-by position, it locks under the fixed frame using its unique patented system.

Operating system

A manually initiated device (DCM) controls the system, pneumatic opening and closing, that complies with NF S 61-938. The smoke exhaust vent is equipped with a factory-installed thermofuse, rated at 93°C, to command opening.

Kerb

The kerb is made from galvanised sheet steel. It is 400mm in height. Thermal insulation is provided by a 15mm thick rock wool insulation layer.

ISO+ range

The ISO+ reinforced insulation range limits heat loss: 30% improvement compared with a standard unit.

Glazing

Opalescent multiwall polycarbonate (MWPC) lid, 10mm thick for the standard version. It is integrated into a fully sealed aluminium F frame. Fire rating: B-s1.d0 (M1). (Different types of glazing available)

Pneumatic Drives

Both pneumatic drives are equipped with stroke end cushioning.

Wind baffles

(for the HPA version)

Fitted with metal wind baffles for better smoke ventilation efficiency and resistance to outdoor elements.

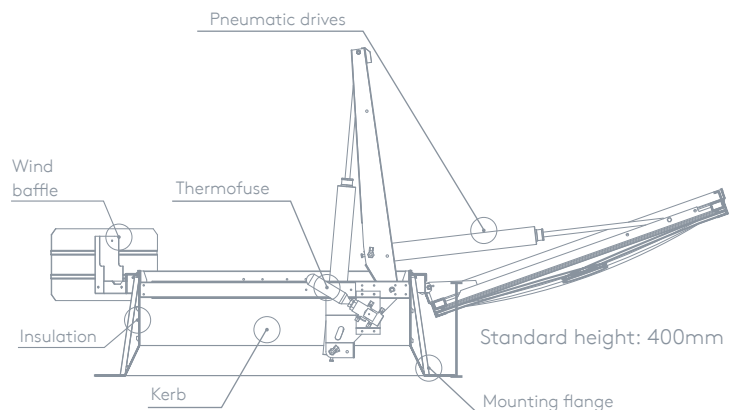
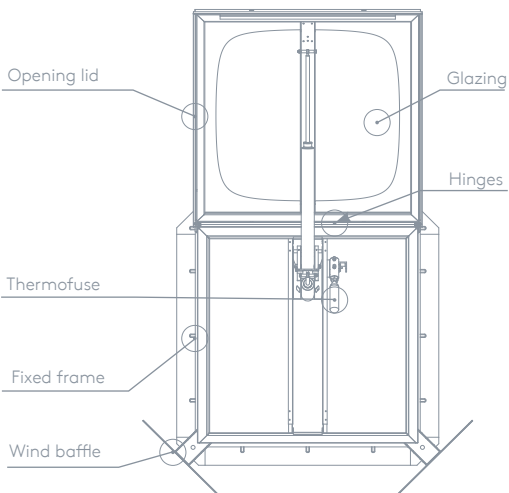
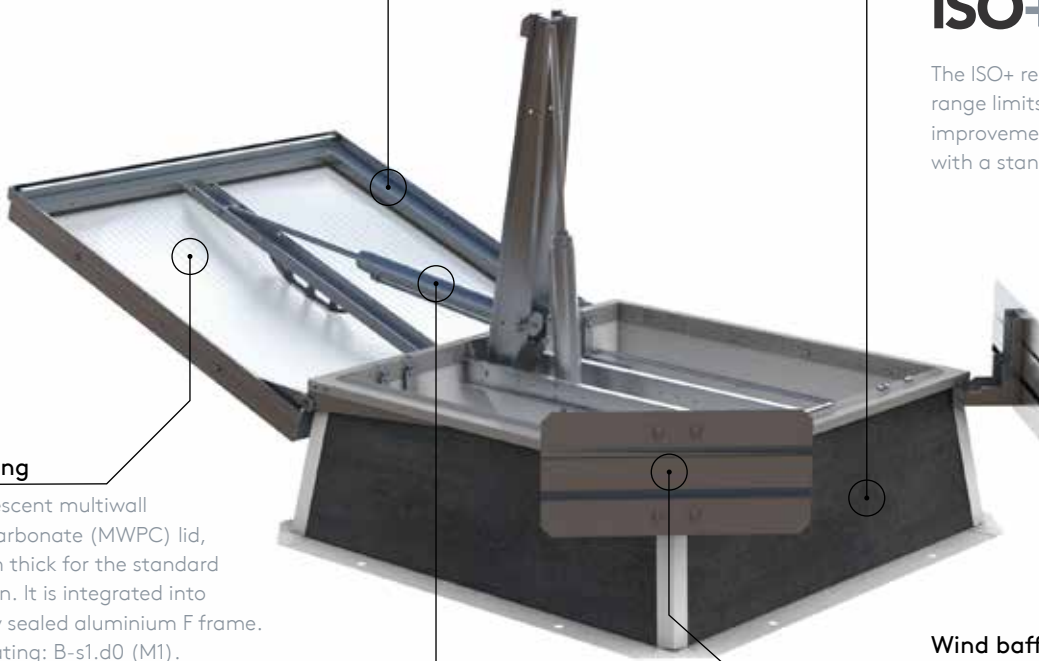



Ecofeu PN 160 | Aeraulic performance

Dimensions & aeraulic performance																
Aa (aerodynamic free area of smoke exhaust ventilator) = Aa in m ² / Av (geometric area of smoke exhaust ventilator) = Width (W) x Length (L) = Av in m ²																
W (cm) \ L (cm)	100	110	120	130	140	150	160	170								
100	0.69	0.63														
110	0.76	0.70	0.80	0.73												
120	0.82	0.75	0.87	0.80	0.92	0.85										
130	0.89	0.82	0.95	0.88	0.99	0.92	1.04	0.97								
140	0.96	0.89	1.02	0.95	1.07	1.00	1.11	1.04	1.15	1.08						
150	1.02	0.95	1.09	1.02	1.14	1.07	1.19	1.12	1.23	1.16	1.26	1.19				
160	1.09	1.02	1.16	1.09	1.21	1.14	1.27	1.20	1.31	1.24	1.34	1.28	1.37	1.31		
170	1.15	1.08	1.22	1.15	1.29	1.22	1.34	1.27	1.39	1.33	1.42	1.36	1.45	1.40	1.48	1.44
180	1.22	1.15	1.29	1.22	1.36	1.29	1.42	1.35	1.46	1.40	1.50	1.45	1.54	1.50		
190	1.28	1.21	1.36	1.29	1.43	1.36	1.49	1.43	1.54	1.49	1.58	1.54	1.62	1.59		
200	1.35	1.28	1.43	1.36	1.50	1.44	1.57	1.51	1.62	1.57	1.66	1.62	1.70	1.68		
210	1.41	1.34	1.50	1.43	1.57	1.51	1.64	1.59	1.69	1.65						
220	1.48	1.41	1.57	1.51	1.64	1.59	1.71	1.67	1.77	1.74						
230	1.54	1.47	1.63	1.57	1.71	1.66	1.79	1.75	1.85	1.83						
240	1.64	1.58	1.73	1.68	1.78	1.74	1.86	1.85	1.92	1.91						
250	1.71	1.65	1.80	1.75	1.88	1.84	1.94	1.92	1.99	1.99						
260	1.77	1.71	1.87	1.83												
270	1.84	1.79	1.94	1.90												
280	1.91	1.86	2.01	1.98												
290	1.97	1.93	2.08	2.06												
300	2.04	2.00	2.15	2.13												

■ SL500 possible on request □ Available in roof access version □ Not available with pneumatic ventilation
Aa Standard (m²) / Aa with anti-fall and anti-burglary protection grid (RE) (m²)



Ecofeu PN 160 HPA | Aeraulic performance with wind baffles

Dimensions & aeraulic performance																
Aa (aerodynamic free area of smoke exhaust ventilator) = Aa in m ² / Av (geometric area of smoke exhaust ventilator) = Width (W) x Length (L) = Av in m ²																
W (cm) \ L (cm)	100	110	120	130	140	150	160	170								
100	0.81 / 0.75															
110	0.89 / 0.83	0.97 / 0.90														
120	0.96 / 0.89	1.06 / 0.99	1.15 / 1.08													
130	1.04 / 0.97	1.14 / 1.07	1.24 / 1.17	1.34 / 1.27												
140	1.12 / 1.05	1.22 / 1.15	1.33 / 1.26	1.43 / 1.36	1.54 / 1.47											
150	1.19 / 1.12	1.31 / 1.24	1.42 / 1.35	1.53 / 1.46	1.65 / 1.58	1.75 / 1.68										
160	1.27 / 1.20	1.39 / 1.32	1.51 / 1.44	1.63 / 1.56	1.75 / 1.68	1.83 / 1.77	1.91 / 1.82									
170	1.35 / 1.28	1.48 / 1.41	1.60 / 1.53	1.73 / 1.66	1.83 / 1.77	1.91 / 1.85	1.98 / 1.93	2.05 / 2.01								
180	1.22 / 1.15	1.56 / 1.49	1.69 / 1.62	1.82 / 1.75	1.90 / 1.84	1.98 / 1.93	2.06 / 2.02									
190	1.50 / 1.43	1.64 / 1.57	1.78 / 1.71	1.89 / 1.83	1.97 / 1.92	2.05 / 2.01	2.13 / 2.10									
200	1.58 / 1.51	1.73 / 1.66	1.87 / 1.81	1.96 / 1.90	2.04 / 1.99	2.13 / 2.09	2.21 / 2.19									
210	1.65 / 1.58	1.81 / 1.74	1.94 / 1.88	2.03 / 1.98	2.11 / 2.07											
220	1.73 / 1.66	1.89 / 1.83	2.01 / 1.96	2.10 / 2.06	2.18 / 2.15											
230	1.81 / 1.74	1.98 / 1.92	2.08 / 2.03	2.17 / 2.13	2.26 / 2.24											
240	1.88 / 1.82	2.05 / 2.00	2.14 / 2.10	2.24 / 2.21	2.33 / 2.32											
250	1.96 / 1.90	2.12 / 2.07	2.21 / 2.17	2.31 / 2.29	2.35 / 2.35											
260	2.04 / 1.98	2.18 / 2.14														
270	2.11 / 2.06	2.25 / 2.21														
280	2.19 / 2.14	2.31 / 2.28														
290	2.26 / 2.22	2.38 / 2.36														
300	2.34 / 2.30	2.45 / 2.43														

■ SL500 possible on request □ Available in roof access version □ Not available with pneumatic ventilation
Aa Standard (m²) / Aa with anti-fall and anti-burglary protection grid (RE) (m²)

Performance and classifications (according to EN 12101-2)*

Name	Class	Meanings / Observations
Functioning	Type B	Opening and closing from the ground
Useful surface area	Aa	See "Dimensions and aeraulic performance" table
Reliability	RE 300 (10,000 cycles in ventilation)	Number of open/close smoke ventilation test cycles
Snow load	SL250	Permissible load in N/m ² in the smoke ventilation test
Wind load	WL 1500	Resistance to wind suction force (in N/m ²)
Low temperature	T (00)	Unit meets French requirements
Resistance to heat	B300	Operating test at a temperature of 300°C

* The exact technical specifications depend on the dimensions of the units. To be checked on a case-by-case basis.

Terms and conditions of use

Name	Class
Minimum opening pressure (smoke ventilation)	10 bar*
Minimum opening pressure (ventilation)	6 bar*
Minimum reclosing pressure	8 bar*
Maximum inclination and orientation for the kerb bearing plane	21° hinge pin parallel to the ridge and at the top

* The exact technical specifications depend on the dimensions of the units. To be checked on a case-by-case basis.

Installation examples

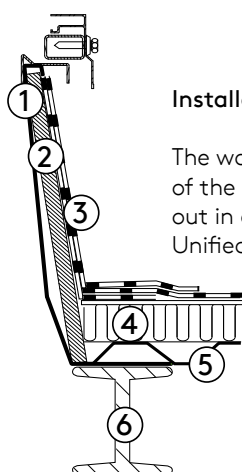

Installation of kerb - weathering

The waterproofing and the fastening of the kerb to the support must be carried out in accordance with the applicable Unified Technical Document (D.T.U.)

1. Kerb
2. Kerb insulation
3. Waterproofing
4. Roof insulation
5. Steel roof deck
6. Joist

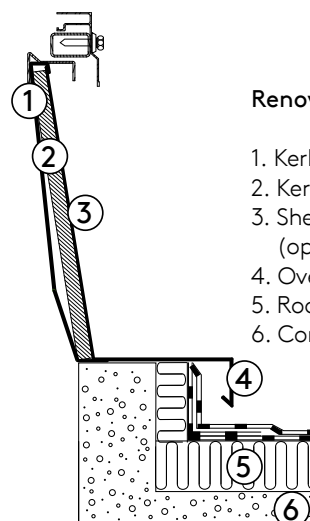

Renovation set-kerb

1. Kerb
2. Kerb insulation (optional)
3. Sheet metal laminate (optional)
4. Overlap
5. Roof insulation
6. Concrete slab

Options

Kerb and equipment

**1. Anti-fall and anti-burglary protection grid (RE)
1,200 Joules**

The Kingspan Light + Air RE grid complies with CRAM recommendations for the protection of personnel working on roofs, and is in conformity with the



French Labour Code. It passed the standardised test for resistance to a person tripping and falling over: dynamic 1,200 Joule test (see datasheet).

2. Kerb equipped for PVC waterproofing

The insulation is laid upside down at a manufacturing stage, with the non-bituminous side facing outwards to allow the PVC membrane to be assembled and fixed with the omegas supplied.

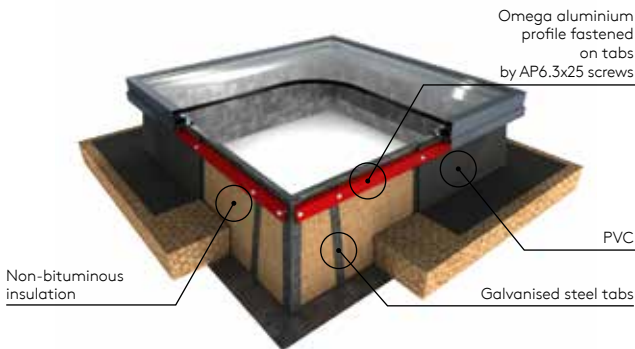

3. Stroke end contacts

Two position contacts (safety position / standby position) can be connected to a control panel.

This system allows the positions of all the installation's exhaust vents to be checked without climbing on the roof. This option is required when installing the SHEV in a Category A or B Fire Safety System.



4. Reinforced thermal insulation

The ISO+ reinforced insulation range provides better airtightness and reduces heat loss thanks to more efficient MWPC glazing (16 or 32mm), an insulating seal between the lid and the kerb, and improved kerb insulation (30mm).

I.e. a 30% improvement in heat efficiency compared with a standard unit. $U_{rc} = 1.7 \text{ W/m}^2\cdot\text{K}$

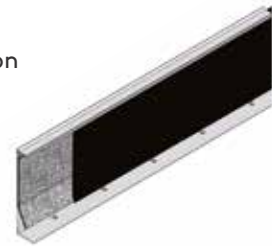

ISO+ range

5. Without thermofuse

Useful option, for example, if regulations require the fire detection system to control smoke ventilation.

6. Painting

The inside of the kerb and security bars are supplied already painted: all RAL colours available on request.

Specially for Renovation

**Renovation set for
160° opening system**

The steel renovation set for smoke exhaust vents, CE and NF-certified, with a 160° opening, is designed for renovation and compliance retrofit work (see datasheet).

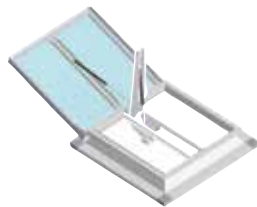

Specially for Roof Access

Roof access

To ensure easy access to the roof, the smoke exhaust vent is equipped with a remote mechanism, hand rail, opening RE grid and a bar to attach a ladder (see datasheet).

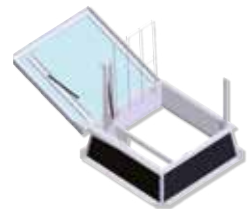

Ventilation

160° pneumatic ventilation



This is included with the unit without modification, at no additional cost. Simply connect the unit to a comfort box, which enables smoke extraction and ventilation. CE certification is also valid in this configuration. (Caution, the ventilation function is not available for the 130 x 250cm version).

Electric ventilation

Ventilation can also be ensured by a 230V electric drive with a 300mm stroke. Depending on the smoke to be extracted, the electric spindle is unlocked automatically.



Types of glazing

1. MWPC lid

Our multiwall polycarbonate proposals.
Other characteristics on request.



2. Polyester lid and dome

Completely opaque lid with black interior to avoid any light reflection.

It is suitable for use on sites where overhead lighting is to be avoided: cellar, chemical sites, cinemas, etc. Also for sites exposed to aggressive chemical products.

Thickness: 25mm. Light transmission: 0%.

Thermal transmittance coefficient:

$U = 0.8 \text{ W/m}^2\cdot\text{K}$.

3. Aluminium lid

This lid has the best fire rating. Thickness: 50mm.

Light transmission: 0%.

Thermal transmittance coefficient:

$U = 0.8 \text{ W/m}^2\cdot\text{K}$. Fire rating: A2 – s1, d0 (M0).

Not combustible.

4. Sound-proofing

Insulated aluminium lid 50mm thick.

According to CSTB tests, 29 dB Rw acoustic reduction.

5. PMMA dome

Polymethylmethacrylate dome. Single or double wall.

Fire rating: E (M4).

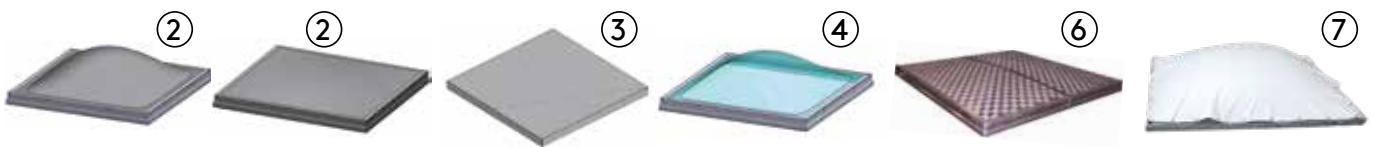

Polycarbonate Version	Thickness	Number of walls
Opalescent	10 mm	4
	16 mm	5
	16 mm	7
	32 mm	5
Translucent	10 mm	4
	16 mm	5
	16 mm	7
	32 mm	5
Heat reduction	10 mm	4
	16 mm	5
	16 mm	7
	32 mm	5
Grey opaque	10 mm	4
	16 mm	7

For any other requirements, please contact us.

Solar protection

6. Ecosun solar protection

The Ecosun solar protection provides a sustainable and economical solution to the problem of overheating in buildings. It is a high performance aluminium system, combined with the multiwall polycarbonate glazing in our rooflights. CSTB tests show that the energy transmission factor is only 15% (see datasheet).

7. Detachable external sun screens

Made to measure tarpaulin, PVC coated for a longer lifetime, with strengthened edges and eyelets. These screens are delivered ready to be installed, and are secured using a bungee cord threaded through the eyelets.

Kingspan Light + Air at your service:

Kingspan Light + Air is a manufacturer as well as a service provider with a network of service engineers and in-house CFD and fire engineering expertise. Proper, preventative, pre-emptive maintenance of Smoke & Heat Exhaust Systems undertaken by qualified specialists will not only ensure the highest levels of safety and security but also mean savings in time and money.

The comfort of a partner who takes care of everything: ask your local representative for more information about the services available in your country.



Certifications



INTERNATIONAL

Kingspan Light + Air

E: kla.international@kingspan.com

www.kingspanlightandairinternational.com

For the product offering in other markets please contact your local sales representative or visit www.kingspanlightandairinternational.com

Care has been taken to ensure that the contents of this publication are accurate, but Kingspan Limited and its subsidiary companies do not accept responsibility for errors or for information that is found to be misleading. Suggestions for, or description of, the end use or application of products or methods of working are for information only and Kingspan Limited and its subsidiaries accept no liability in respect thereof.